

Main Truck Specifications

		CTB GROUP											
Specifications	1	Manufacturer											
	2	Model		Power shift T/M	FG30T	FG35T	FD30T	FD35T	FD30T	FD35T	FD40T		
	3	Load capacity		Manual shift T/M	FG30C	FG35C	FD30C	FD35C	FD30C	FD35C	FD40C		
	4	Load center		kg	3000	3500	3000	3500	3000	3500	4000		
	5	Power unit		mm	500		500		500		500		
	6	Operator type			Gasoline/LPG		Diesel		Diesel		Diesel		
	7	Tire type		Front/rear	Driver/seat		Driver/seat		Driver/seat		Driver/seat		
	8	Wheel		Front/rear	Pneumatic		Pneumatic		Pneumatic		Pneumatic		
Dimension	9	Max. lifting height		mm	3000		3000		3000		3000		
	10	Free lift		mm	150		150		150		150		
	11	Fork size L x W x T		mm	1070x125x45	1070x125x50	1070x125x45	1070x125x50	1070x125x45	1070x125x50	1070x150x50		
	12	Tilt angle Mast forward/backward		deg	6 / 12		6 / 12		6 / 12		6 / 12		
	13	Overall length(without fork)		mm	2705	2760	2705	2760	2705	2760	2870		
	14	Total width		mm	1225	1285	1225	1285	1225	1285	1365		
	15	Mast height (fork lowering)		mm	2075		2075		2075		2150		
	16	Overall height fork raised(with backrest)		mm	4250		4250		4250		4250		
	17	Height to head guard		mm	2140		2140		2140		2140		
	18	Turning radius(outside)		mm	2445	2495	2445	2495	2445	2495	2530		
	19	Load distance		mm	480	485	480	485	480	485	485		
	20	Right angle stacking aisle(not add load length&clearance)		mm	2925	2975	2925	2975	2925	2975	2940		
Performance	21	Speed	Max. travelling	full load	km/h	18		18		18		16.5	
	no load			km/h	19.5		19.5		19.5		18		
	Lifting		full load	mm/s	450	450	450	450	450	450	380		
			no load	mm/s	500	500	500	500	500	500	480		
	Lowering		full load	mm/s	450	450	450	450	450	450	450		
			no load	mm/s	450	420	450	420	450	420	420		
24	Max. drawbar pull	Power shift T/M	full/no load	kg	1300/1000	1800/1000	1500/1000	2200/1000	1500/1000	2100/1000	2200/1000		
Manual shift T/M		full/no load	kg	1350/1000	1900/1000	1550/1000	2200/1000	1550/1000	2100/1000	2200/1000			
25	Gradeability at 1.6km/h	Power shift T/M	full/no load	%	17/20	17/20	18/20	18/20	18/20	18/20	18/20		
		Manual shift T/M	full/no load	%	17/20	17/20	18/20	18/20	18/20	18/20	18/20		
Weight	26	Truck weight		kg	4300	4700	4380	4780	4380	4780	5050		
	27	Weight distribution	Full load	front axle	kg	6450	7340	6490	7380	6490	7380	7890	
				rear axle	kg	850	860	890	900	890	900	1140	
			No load	front axle	kg	1630	1790	1670	1820	1670	1820	1810	
rear axle				kg	2670	2910	2700	2960	2700	2960	3240		
Chassis & Wheels	29	Number		front/rear	2 / 2		2 / 2		2 / 2		2/2		
	30	Tires	Model	front	28x9-15-12PR		28x9-15-12PR		28x9-15-12PR		250-15-16PR		
			rear	6.50-10-10PR		6.50-10-10PR		6.50-10-10PR		6.50-10-10PR			
	32	Wheelbase		mm	1700		1700		1700		1800		
	33	Tread	Front	mm	1000	1060	1000	1060	1000	1060	1120		
			Rear	mm	970		970		970		970		
	34	Ground clearance	At lowest point(mast)	mm	120		120		120		120		
Frame			mm	135		135		135		135			
35	Brake	Service brake	Hydraulic-foot pedal				Hydraulic-foot pedal						
		Parking brake	Mechanical-hand lever				Mechanical-hand lever						
Drive line	36	Battery		V/AH	12/60		12/80		12/80		12/80		
	37	Engine	Model		NISSAN K21	NISSAN K25	ISUZU C240	Mitsubishi S4S	ISUZU C240	DACHAICA498	ISUZU 4JG2		
			Rated power	KW/rpm	31.2/2250	37.4/2300	34.3/2500	35.4/2250	34.3/2500	42/2450	44.8/2450		
			Rated torque	N-m/rpm	144/1600	177/1600	138/1800	170/1700	138/1800	190/1800	186/1800		
			Number of cylinder		4	4	4	4	4	4	4		
38	Fuel tank capacity		L	70		70		70		70			
39	Transmission	Speed forward/backward	Power shift T/M	1-1 power shift T/M				1-1 power shift T/M					
			Manual shift T/M	2-2 manual shift T/M				2-2 manual shift T/M					
40	Operating pressure		Hydraulic system pressure	kg/cm ²	180		180		180		180		

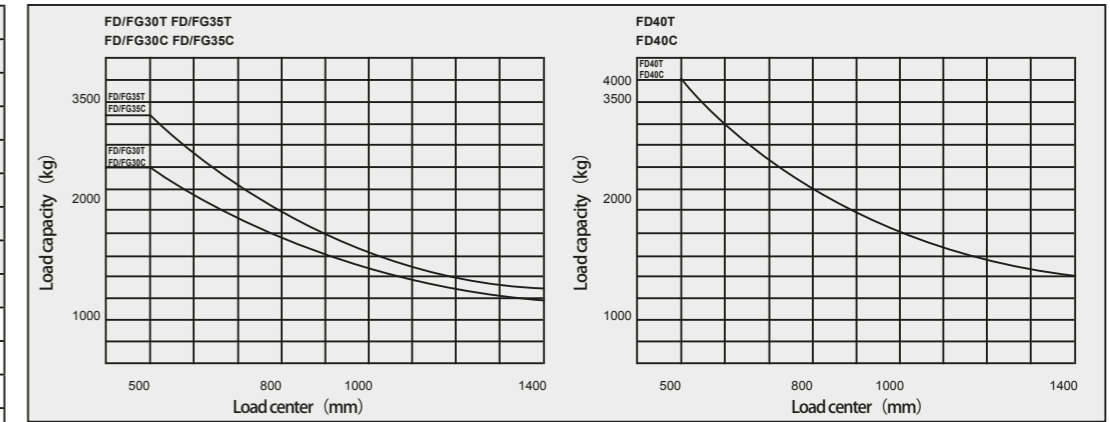

Notes:
 Vertical axis represents load capacity; Horizontal axis shows load center, Load center are determined from front face of the fork. Capacity based on a 1000mm cube load configuration with the center of gravity at the true center of the cube, and standard fork. The load capacity will be reduced while the mast tilt forward or loading with long fork or lifting transformable width of goods. Getting the load capacities at the various load centers timely via the load curve.
 CTB products and specifications change without prior notice.
 CTB forklift truck has equipped with standard safety device.
 CTB is not responsible for the damage occurred by removing its safety device.

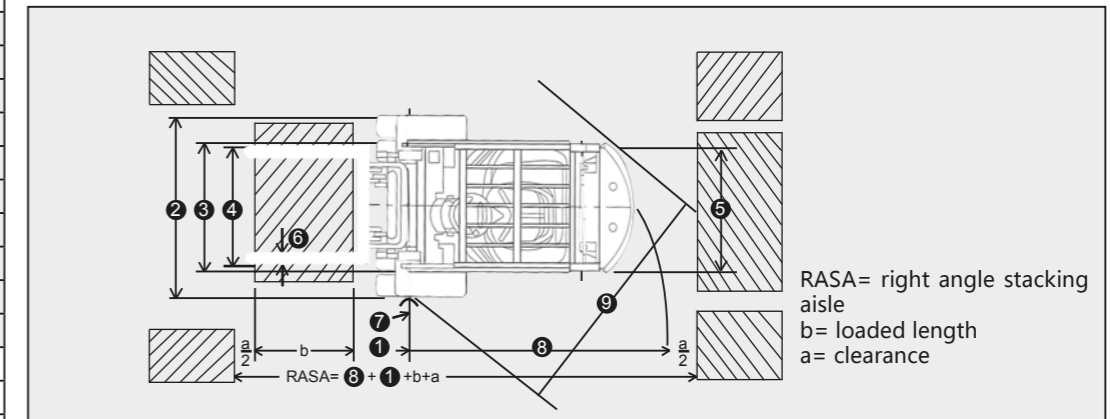

Specifications(front single tires)

Model	FG/D30C - FG/D30T	FG/D35C - FG/D35T	FD40C - FD40T
	(mm)	(mm)	(mm)
① Front Overhang	480	485	485
② Total Width	1225	1285	1365
③ Front Track	1000	1060	1120
④ Fork Spread(outside)	250~1090	250~1190	250~1190
⑤ Rear Track	970	970	970
⑥ Fork Width	125	125	150
⑦ Turning Radius(inside)	200	200	200
⑧ Turning Radius(outside)	2445	2495	2530
⑨ Right Angle Turning Aisle	2155	2205	2450

Standard equipments:

Wide view mast, Cyclone air cleaner, Load one-way valve, Preheat indicator, King Pin, Engin-start switch, Standard backrest, Long-life tires, Overhead guard, Oil and water separator, Power steering, Adjustable steering column, Radiator water tank, Side roller, Standard carriage, Oil temperature cooler, Headlamp and steering indicator lamp, Charge indicator lamp, Hour meter, Oil warning light of engin, Water temperature gauge, Fuel gauge, Reversing light, Electric horn, Neutral-safety switch, Rear mirror, Tools, Reversing Buzzer, General seat.

Options:

Fire extinguisher, cab, Heater unit, Rear work light, Solid tires, Fireproof silencer, Upper exhaust pipe, Tilt cylinder jacket, Rotating warning light, LPG Conversion device, Pre-filtration air intake device.

Attachments:

Side shifter, Fork positioned, Carpet boom, Fork extension, Long fork flat clamp, Others

Note: There's also Yanmar 4TNE98, Chinese Xinchai C495 diesel engine for option, and the specs will be little different.

Wide view mast VM

Mast model	Load center 500mm			Max.lift height	Mast height			Tilt angle fwd-bwd	(3) Weight		
	FG/D 30	FG/D 35	FD 40		fork lowered		(1)fork lift with backrest		FG 30	FG 35	FD 40
					FG/D 30 35	FD 40					
kg	kg	kg	mm	mm	mm	mm	deg	kg	kg	kg	
VM250	3000	3500	4000	2500	1825	1900	3750	6 - 12	4270	4650	5000
VM270	3000	3500	4000	2700	1925	2000	3950	6 - 12	4285	4670	5020
VM300	3000	3500	4000	3000	2075	2150	4250	6 - 12	4300	4700	5050
VM330	3000	3500	4000	3300	2225	2300	4550	6 - 12	4335	4730	5080
VM350	3000	3500	4000	3500	2325	2400	4750	6 - 12	4350	4750	5100
VM400	3000	3500	4000	4000	2625	2700	5250	6 - 6 * 6 - 12	4430	4835	5185
VM450	2900 * 3000	3000 * 3500	3400 * 4000	4500	2875	2950	5750	6 - 6 * 6 - 12	4470	4780	5225
VM500	2700 * 2850	2800 * 3300	3200 * 3700	5000	3125	3200	6250	6 - 6 * 6 - 6	4515	4930	5300
VM550	* 2400	* 2700	* 3100	5500	3425	3500	6750	* 3 - 6	4740	5160	5495
VM600	* 2000	* 2300	* 2700	6000	3675	3750	7250	* 3 - 6	4780	5205	5535

2 Stage free lift mast VFM

Mast model	Load center 500mm			Max.lift height	Mast height			(2)free lift with backrest	Tilt angle fwd-bwd	(3) Weight		
	FG/D 30	FG/D 35	FD 40		fork lowered		(1)fork lift with backrest			FG 30	FG 35	FD 40
					FG/D 30 35	FD 40						
kg	kg	kg	mm	mm	mm	mm	deg	kg	kg	kg		
VFM250	3000	3500	4000	2500	1825	1875	3760	600	6 - 12	4330	4720	4970
VFM270	3000	3500	4000	2700	1925	1975	3960	700	6 - 12	4350	4740	4990
VFM300	3000	3500	4000	3000	2075	2125	4260	850	6 - 12	4380	4770	5020
VFM330	3000	3500	4000	3300	2225	2275	4560	1000	6 - 12	4405	4795	5045
VFM350	3000	3500	4000	3500	2325	2375	4760	1100	6 - 12	4425	4815	5065

3 Stage free lift mast VFHM

Mast model	Load center 500mm			Max.lift height	Mast height			(2)free lift with backrest	Tilt angle fwd-bwd	(3) Weight		
	FG/D 30	FG/D 35	FD 40		fork lowered		(1)fork lift with backrest			FG 30	FG 35	FD 40
					FG/D 30 35	FD 40						
kg	kg	kg	mm	mm	mm	mm	mm	deg	kg	kg	kg	
VFHM360	3000	3500	4000	3600	1825	1825	4860	600	6 - 6 * 6-10	4490	4880	5130
VFHM400	3000	3500	4000	4000	1950	1950	5260	725	6 - 6 * 6-10	4525	4915	5165
VFHM435	2900 * 3000	3200 * 3500	3650 * 4000	4350	2075	2075	5660	850	6 - 6 * 6-10	4560	4950	5200
VFHM450	2850 * 3000	3100 * 3500	3540 * 4000	4500	2150	2150	5760	925	6 - 6 * 6-10	4575	4970	5225
VFHM480	2800 * 2900	2900 * 3400	3310 * 3880	4800	2225	2225	6060	1000	6 - 6 * 6-10	4595	4985	5235
VFHM500	2600 * 2700	2800 * 3100	3200 * 3540	5000	2325	2325	6260	1100	6 - 6 * 6 - 10	4625	5015	5265
VFHM550	1900 * 2650	2000 * 2700	2280 * 3085	5500	2460	2460	6760	1250	3 - 6 * 6 - 6	4675	5050	5300
VFHM600	1400 * 2100	1500 * 2300	1700 * 2630	6000	2675	2675	7260	1450	3 - 6 * 3 - 6	4750	5140	5390
VFHM650	* 1700	* 1700	* 1940	* 6500	2890	2890	7760	1665	* 3 - 3	4965	5350	5600
VFHM700	* 1350	* 1350	* 1540	* 7000	3110	3110	8260	1885	* 3 - 3	5020	5410	5660

Notes: (1) Max. Lift height (without backrest): -580mm (2) Free lift height without backrest: +580mm; Weight without backrest: -30kg (3) Diesel forklift weight: +80kg

Notes: The mark of * is with double tires, the weight with double tires: +150kg

Lift speed with VFM/VFHM VFM: FG 400mm/s full load, 450mm/s no load; FD400mm/s full load, 420mm/s no load.

VFHM: FG 410mm/s full load, 470mm/s no load; FD420mm/s full load, 440mm/s no load.

Lowering speed: VFM/VFHM 400mm/s full load, 300mm/s no load.



CTB GROUP

Ctra. Prats de Lluçanes 550
Pol. Ind. La Lanera - Nave 3
08208 Sabadell (Spain)
Tel.: +34 937 168 782
Fax.: +34 937 171 468
www.ctbgroup.es

Distributor



FD/G Series 30 40 Counter Balanced Forklift



Three Features



1 Cleaner, more efficient Engines

New engines, compliant with worldwide stage III A emission regulations (ISUZU C240PKJ, Mitsubishi S4S Diesel powered engine).

2 Easy Maintenance

Detachable side covers and a wide-opening hood for convenient inspection and simple maintenance. Integral layout of electrical parts and other system devices.



3 Easier entry and exit from an extra-wide step

The secure step with enlarged foot space enables greater comfort and less fatigue while entering and exiting the vehicle.

