

Technický list :

AETJ 49



Capacities		Metrické	Anglosaské
Working height	h21	16.9 m	55 ft 5 in
Platform height	h7	14.9 m	48 ft 11 in
Max. outreach	l4	9.43 m	30 ft 11 in
Overhang	l5	7 m	23 ft
Pendular arm rotation (top / bottom)		+65 ° / -65 °	+65 ° / -65 °
Platform capacity	Q	227 kg	500 lbs
Turret rotation		355 °	355 °
Platform rotation (right / left)		66 ° / 59 °	66 ° / 59 °
Number of people (inside / outside)		2 / 2	2 / 2
Weight and dimensions			
Platform weight*		7095 kg	15642 lbs
Platform dimensions (length x width)	lp / ep	1.2 m x 0.92 m	3 ft 11 in x 3 ft
Overall width	b1	1.75 m	5 ft 9 in
Overall length	l1	6.84 m	22 ft 5 in
Overall height	h17	1.97 m	6 ft 6 in
Overall length (stowed)	l9	5.12 m	16 ft 10 in
Overall height (stowed)	h18	2.04 m	6 ft 8 in
Floor height (access)	h20	0.4 m	1 ft 4 in
Jib length	l13	1.26 m	4 ft 2 in
Counterweight offset (turret at 90°)	a7	0.08 m	3 in
Internal turning radius (over tyres)	b13	2 m	6 ft 7 in
External turning radius	Wa3	4.3 m	14 ft 1 in
Tailswing		0.08 m	3 in
Ground clearance at centre of wheelbase	m2	0.14 m	6 in
Wheelbase	y	2 m	6 ft 7 in
Performances			
Drive speed - stowed		5 km/h	3.1 mph
Drive speed - raised		0.6 km/h	0.4 mph
Gradeability		22 %	22 %
Permissible leveling		3 °	3 °
Wheels			
Tyres type		Solid non-marking tires	Solid non-marking tires
Dimensions of front wheels / rear wheels		0,60x0,19m - 0,60x0,19m	0,60x0,19m - 0,60x0,19m
Drive wheels (front / rear)		0 / 2	0 / 2
Steering wheels (front / rear)		2 / 0	2 / 0
Braking wheels (front / rear)		0 / 2	0 / 2
Engine/Battery			
Electric engine power rating		2 x 4.5 kW	2 x 4.5 kW
Electric Pump		3.7 kW	3.7 kW
Battery / Batteries capacity		48 V / 240 Ah	48 V / 240 Ah
Integrated charger (V / Ah)		48 V / 30 mAh	48 V / 30 mAh
Miscellaneous			
Number of cycles with STD Battery (HIRD)		44	44
Ground Pressure		16.6 daN/cm ²	16.6 daN/cm ²
Hydraulic Pressure		210 Bar	14 PSI
Hydraulic tank capacity		15 l	3.30 gal
Vibration on hands/arms		< 2.5 m/s	< 8.2 ft/s
Standards compliance			
This machine is in compliance with:		Evropské směrnice: 2006/42/ES - Strojní zařízení (revidovaná EN280:2013) - 2004/108/ES (EMC) - 2006/95/ES (Nízké napětí)	Evropské směrnice: 2006/42/ES - Strojní zařízení (revidovaná EN280:2013) - 2004/108/ES (EMC) - 2006/95/ES (Nízké napětí)

Rozměrový výkres

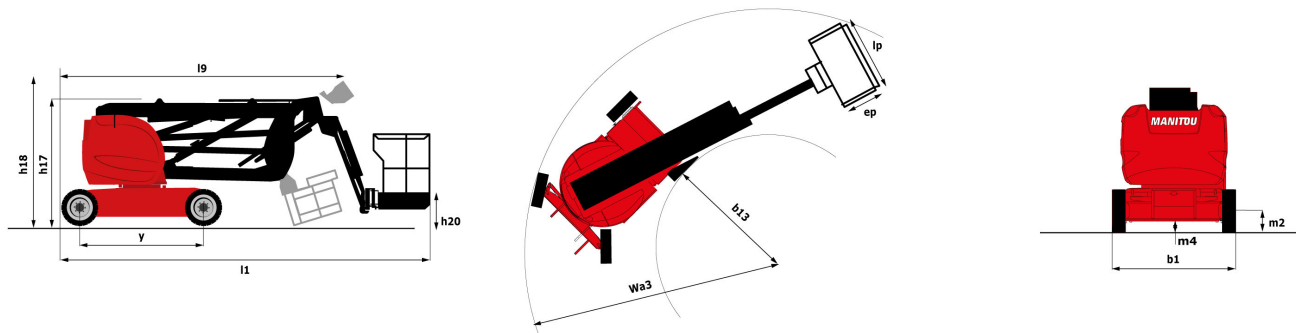

Nářadí

Standardní

- 110 V plug with differential circuit breaker
- Audible alarm and illuminated indicator lamp (leveling, overload, lowering)
- Battery charge indicator lamp
- CAN bus technology
- Drive safety orientation system
- Electric predisposition on boom
- Emergency stop button in platform and on frame
- Horn in the platform
- Hour meter
- Integrated diagnostic assistance
- Manual emergency lowering
- Multi-voltage integrated charger
- Negative-type braking on rear wheels
- Non-marking rubber tyres
- Platform access gate
- Proportional controls
- Slings and securing rings
- Tool box in platform
- Traction battery
- Travel possible at maximum height

Volitelné

- Air predisposition
- Beep on every movement
- Beep upon travel
- Biodegradable oil
- Cold weather kit
- Extreme cold oil
- Flashing Light
- Highly capacity battery
- Protective cover for control panel
- SMS : Safe Man System
- Water predisposition
- Working headlight in platform

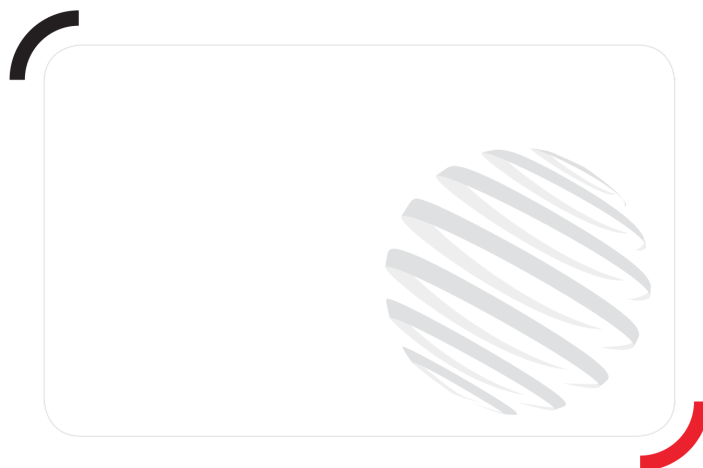

Siège Social
430 rue de l'Aubinière - 44150 Ancenis Cedex - France
Tel: +33(0)2 40 09 10 11 - Fax: +33 (0)2 40 09 10 97
www.manitou.com



Tato brožura popisuje verze a možnosti konfigurace pro produkty Manitou, které lze montovat s různým vybavením. Vybavení popsaná v tomto dokumentu mohou být standardní, volitelná nebo nedostupná v závislosti na verzi. Společnost Manitou si vyhrazuje právo na změnu uvedené a popsané specifikace kdykoliv a bez předchozího upozornění. Výrobce není odpovědný za uvedené specifikace. Pro více informací se obraťte na svého prodejce Manitou. Mimosmluvní dokument. Popisy produktů se mohou lišit od skutečných produktů. Seznam specifikací není úplný. Loga a vizuální identifikace společnosti jsou majetkem společnosti Manitou a nemohou být použity bez povolení. Všechna práva vyhrazena.

Fotografie a diagramy obsažené v této brožuře jsou poskytovány pouze pro informaci. MANITOU BF SA - Společnost s ručením omezeným s dozorčí radou - Základní kapitál: 39 668 399 v měně euro - 857 802 508 RCS Nantes

Intenzita elektrického proudu